

# Sliding Table Saw Blades

## Panel Sizing

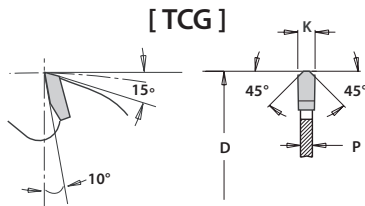
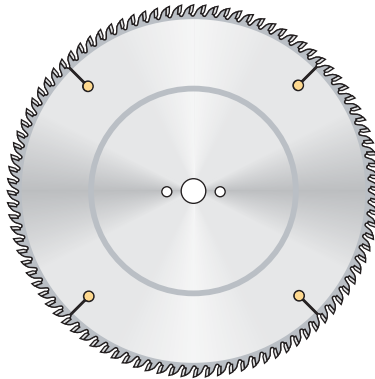

**Application:** For cutting single or multiple sheets with sliding table saws with or without scoring capabilities. Manufactured for moderate to high production and tight tolerance for a straight and true cut everytime.

Carbide-tipped | TCG Top Design | Copper Plugged Slots

Catalog #	Dia.	Teeth	Bore	Kerf	Plate
STP30080303	300 mm	80	30 mm	3.2	2.2
STP300100303	300 mm	100	30 mm	3.2	2.2
STP35580303	14"	80	30 mm	3.7	2.7
STP355100303	14"	100	30 mm	3.7	2.7
STP300100303	300 mm	100	30 mm	3.2	2.2
STP350100303	350 mm	100	30 mm	3.6	2.4
STP30080303-1	300 mm	80	30 mm	4.3	3.0

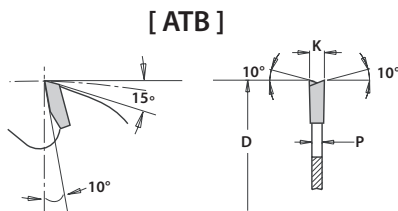
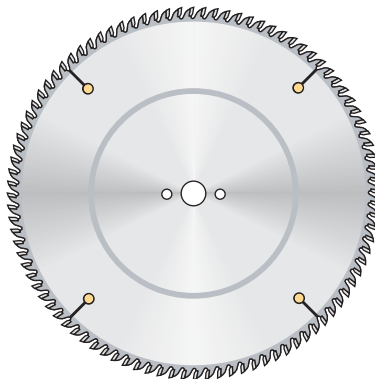

**Application:** For glue line ripping dry soft or hardwoods. Ultra-smooth cut for gluing applications. Use for straight line rip saws, gang saws or table saws.

Carbide-tipped | ATB Top Design | Copper Plugged Slots

Catalog #	Dia.	Teeth	Bore	Kerf	Plate
STP30080302	300 mm	80	30 mm	3.2	2.2
STP300100302	300 mm	100	30 mm	3.2	2.2
STP35580302	14"	80	30 mm	3.7	2.7
STP355100302	14"	100	30 mm	3.7	2.7
STP300100302	300 mm	100	30 mm	3.2	2.2
STP350100302	350 mm	100	30 mm	3.6	2.4
STP30080302	300 mm	80	30 mm	4.3	3.0