



SAW-LECTOR GUIDE

A world of choices in NON-FERROUS SAW BLADES

DIA.	No. OF TEETH	BORE	KERF	PLATE GAUGE	GENERAL PURPOSE SAFETY STYLE 1/4"-3" MATERIAL CATALOG NUMBER	THIN WALL ALUMINUM 1/16"-1/4" WALL THICKNESS CATALOG NUMBER	HEAVY PLATE ALUMINUM 1/2"-6" THICKNESS CATALOG NUMBER	ULTRA-SMOOTH FINISH CUT 1/2"-6" THICK CATALOG NUMBER	1/2" LONG TIP SMOOTH FINISH CATALOG NUMBER
8"	24	5/8"	.120	.095	NFG08241				
8"	60	5/8"	.095	.075		NFT08603			
9"	28	5/8"	.120	.095	NFG09281				
9"	60	5/8"	.105	.085		NFT09603			
10"	30	5/8"	.120	.095	NFG10301				
10"	60	5/8"	.120	.095			NFH10603		
10"	80	5/8"	.115	.095		* NFT10803			
12"	36	1"	.134	.109	NFG12361				
12"	60	1"	.115	.095			NFH12603		
12"	80	1"	.115	.095		NFT12803		NFX12803	
12"	100	1"	.115	.095		* NFT121003			
12"	120	1"	.115	.095		* NFT121203			
14"	48	1"	.134	.109	NFG14481				
14"	60	1"	.150	.120			NFH14603		
14"	72	1"	.150	.120			NFH14723		
14"	80	1"	.134	.109				NFX14803	
14"	100	1"	.130	.105		NFT141003			
16"	48	1"	.150	.120	NFG16481				
16"	60	1"	.150	.120			NFH16603		NFL16603
16"	72	1"	.150	.120			NFH16723		
16"	80	1"	.134	.109				NFX16803	
16"	100	1"	.130	.105		NFT161003			
16"	150	1"	.130	.105		NFT161503			
18"	60	1"	.166	.134	NFG18601				NFL18603
18"	80	1"	.166	.134			NFH18803		
18"	100	1"	.150	.120				NFX181003	
18"	120	1"	.150	.120		NFT181203			
20"	60	1"	.166	.134	NFG20601				NFL20603
20"	80	1"	.166	.134			NFH20603		
20"	100	1"	.150	.120			NFH20803		
20"	120	1"	.166	.134		NFT201203		NFX201003	
20"	130	1"	.166	.134		NFT201303		NFX201203	
24"	60	1"	.166	.134	NFG24601			NFX201303	
24"	72	1"	.166	.134			NFH24603		NFL24603
24"	80	1"	.166	.134			NFH24723		NFL24723
24"	80	1"	.166	.134			NFH24803		
24"	100	1"	.166	.134				NFX241003	
24"	120	1"	.166	.134		NFT241203		NFX241203	

Type NFG - General Purpose, Safety Style
 Type NFT - Thin Wall Extrusion
 Type NFH - Heavy Plate; 1/2" - 6"
 Type NFX - Ultra Smooth Cut on Plate and Extrusion
 Type NFL - Very Smooth Cut on Plate; 1/2" Long Tips

* Hollow Ground Tips on Sides
 Recommended for Cutting Aluminum, Magnesium, Copper, and Brass.
 Excellent Results on Table, Radial Arm or "Chop" Style Machine.

HIGH QUALITY - CARBIDE TIPPED - FINER TOOTH SAWS:
 Recommended for Cutting Light Wall Tubes and Thin Sheet Plates

COARSER TOOTH SAWS:
 Recommended for Cutting Heavy Wall Tubes and Thicker Rolled Plates

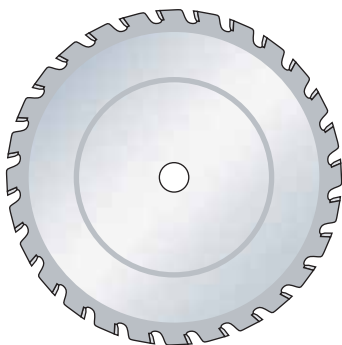

Type NFG - General Purpose

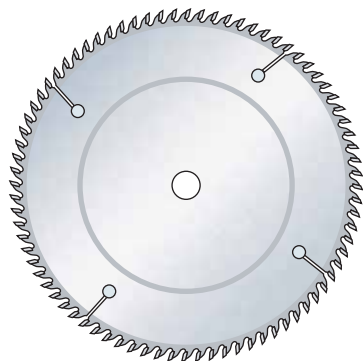

Type NFT - Thin Wall Extrusion



GENERAL SAW CORP.

2518 Andalusia Blvd. | Cape Coral, FL 33909
 Phone: 800-772-3691 | Fax: 239-574-5328 | www.generalsaw.com